

# TB300 IR Turbidimeter



## Instruction Manual

<p><b>Routine Measurement</b></p> <ol style="list-style-type: none"> <li>1. Press [On/Off] key.</li> <li>2. Rinse out a clean vial three times with the sample to be tested. Fill the vial with the sample and cap ensuring that all outside surfaces are clean and dry.</li> <li>3. Place the vial in the sample chamber and align correctly.</li> <li>4. Put on the sample chamber cover (light shield).</li> <li>5. Press [Read] or [Read/Avg] key to start measurement.</li> <li>6. Record the NTU value.</li> </ol> <p>Read/Avg = Measurement with averaging.</p> <p><b>User-Calibration</b></p> <ol style="list-style-type: none"> <li>1. Press [Call] key.</li> <li>2. Place the &lt;0.1 NTU standard in the sample chamber, making sure that the marks are aligned. Put the sample chamber cover on and press [Read/Avg]. Reading starts automatically after count down.</li> <li>3. Invert the 20 NTU standard and place it into the sample chamber, making sure that the marks are aligned. Put the sample chamber cover on and press [Read/Avg] key. Reading starts automatically after count down.</li> <li>4. Invert the 200 NTU standard and place it into the sample chamber, making sure that the marks are aligned. Put the sample chamber cover on and press [Read/Avg] key. Reading starts automatically after count down.</li> <li>5. Invert the 800 NTU standard and place it into the sample chamber, making sure that the marks are aligned. Put the sample chamber cover on and press [Read/Avg] key. Reading starts automatically after count down.</li> <li>6. Press [↓] key to store or press [ESC] to cancel calibration.</li> </ol>	<p><b>Correct Storing and Handling Standards</b></p> <ul style="list-style-type: none"> <li>• T-CAL standards should always be stored in their original vial.</li> <li>• Store standards between 5 and 25°C. (avoid prolonged exposure to temperatures exceeding 35°C).</li> <li>• Store away from direct sunlight. Vials should be stored in their original box which should be closed when not being used.</li> <li>• Always allow the standard to acclimatise to ambient instrument temperature before use (not to exceed 35°C).</li> <li>• T-CAL Standards have a shelf life of minimum 12 months if stored correctly.</li> </ul> <p><b>Using &lt;0.1 NTU Standard</b></p> <p>After delivery allow the vial to stand for least 24 hours before use. Never shake or invert this &lt;0.1 NTU standard. If the standard has been shaken it can take several hours for all the bubbles dissipate and we suggest the vial is left for at least 24 hours as outlined above. If the standard has been inverted accidentally wait at least 15 minutes before using.</p> <p><b>Preparing and Using Standards –infrequent use</b></p> <p>Note: These instructions apply to all standards excepted the &lt;0.1 NTU standard. If you are using the &lt;0.1 NTU standard follow the instructions above. These instructions apply to standards that have been sitting undisturbed for more than one week or to new standards.</p> <ol style="list-style-type: none"> <li>1. Shake the standard vigorously for 2-3 minutes.</li> <li>2. Let the vial stand undisturbed for 5 minutes.</li> <li>3. Invert the vial between 5-10 times.</li> <li>4. Immediately place the vial in the sample chamber and wait for 1 minute (count down).</li> </ol> <p><b>Preparing and Using Standards –frequent use</b></p> <p>Note: These instructions apply to all standards excepted the &lt;0.1 NTU standard. If you are using the &lt;0.1 NTU standard follow the instructions given above. These instructions apply to frequently used standards (daily or weekly usage).</p> <ol style="list-style-type: none"> <li>1. Invert the vial 10 times.</li> <li>2. Immediately place the vial in the sample chamber and wait for 1 minute (count down).</li> </ol>
--	--

## Safety precautions



Turbidity Standards and T-CAL Standards are formulated for chemical analysis and must not be used for any other purpose. Reagents must not get into the hands of children. Some of the reagents contain substances which are not entirely harmless environmentally. Be aware of the ingredients and take proper care when disposing of the test solution.



Please read the instruction manual before unpacking, setting up or using the turbidimeter. Please read the description completely before performing the test. Be aware of the risks of using the required reagents by reading the MSDS (Material Safety Data Sheets). Failure could result in serious injury to the operator or damage to the instrument.

### MSDS:

[www.orbeco.com](http://www.orbeco.com)



Use the charger unit only with rechargeable batteries. Failure can result in serious injury to the operator or damage to the instrument.

**Do not use charger with non rechargeable batteries.**



The accuracy of the instrument is only valid if the instrument is used in an environment with controlled electromagnetic disturbances according to DIN 61326.

Wireless devices, e.g. wireless phones, must not be used near the instrument.

**Revision\_1 02/2009**

# Table of contents

<b>Part 1 Description</b> .....	5
1.1 General description .....	6
1.2 Functional principle .....	7
1.3 Factory adjustment.....	7
1.4 Important notes .....	7
1.4.1 Guidelines for turbidity measurements .....	7
1.4.2 Cleaning of vials & Sampling vessels .....	8
<b>Part 2 Operating manual</b> .....	9
<b>2.1 Operating</b> .....	10
2.1.1 Commissioning .....	10
2.1.2 Saving data - Important notes .....	10
2.1.3 Replacement of rechargeable batteries resp. Lithium battery.....	10
2.1.4 Charging the rechargeable batteries.....	10
2.1.5 Fuse .....	11
2.1.6 Protective caps .....	11
<b>2.2 Overview of funktion keys</b> .....	12
2.2.1 Overview.....	12
2.2.2 Displaying time and date.....	12
2.2.3 User countdown.....	13
<b>2.3 Operation mode</b> .....	14
2.3.1 Automatic switch off.....	14
2.3.2 Turbidity measurement .....	14
2.3.2.1 Read/ Avg key - measurement with Signal Average.....	14
2.3.2.2 Read key - quick measurement.....	14
2.3.2.3 Perform Turbidity measurement.....	15
2.3.3 Storing results .....	16
2.3.4 Printing results .....	17
2.3.5 User-calibration .....	18
2.3.5.1 When to calibrate.....	18
2.3.5.2 Calibration Procedure.....	18
2.3.6 Calibration Standards.....	19

2.3.6.1	T-CAL Standards - Correct Storage and Handling .....	19
2.3.7	Formazin-Standards - Preparation and Handling .....	20
2.3.7.1	Preparation of Dilution Water .....	20
2.3.7.2	Preparation of 4000 NTU Formazin-stock solution .....	20
2.3.7.3	Preparation of dilutions from the 4000 NTU Formazin-stock solution .....	21
2.3.8	Measurement techniques .....	22
2.3.8.1	Degassing - Removal of Bubbles .....	22
2.3.8.2	Measurement of high turbidity values.....	23
2.3.8.3	Measurement of low turbidity values.....	23
2.3.8.4	Indexing and matching sample vials.....	24
2.3.8.5	Indexing a single sample vials .....	24
2.3.8.6	Indexing a set of sample cells .....	25
<b>2.4</b>	<b>Photometer settings &lt;Mode Menu&gt;</b> .....	<b>27</b>
2.4.1	blank because of technical requirements	
2.4.2	Instrument basic settings 1 .....	31
2.4.3	Printing of stored results.....	35
2.4.4	Recall / delete stored results.....	33
2.4.5 – 2.4.8	blank because of technical requirements	
2.4.9	Instrument basic settings 2 .....	39
2.4.10	Instrument special functions / service.....	39
<b>2.5</b>	<b>Data transfer</b> .....	<b>40</b>
2.5.1	Connection to a Printer .....	40
2.5.2	Data transfer to a personal computer (PC) .....	40
2.5.3	Internet-Updates .....	40
<b>Part 3</b>	<b>Enclosure</b> .....	<b>41</b>
3.1	Unpacking.....	42
3.2	Delivery content .....	42
3.3	blank because of technical requirements	
3.4	Technical Data .....	43
3.5	Abbreviations .....	44
3.6	Trouble-shooting .....	45
3.6.1	Operating messages in the display / error display .....	45



# **Part 1**

## **Descriptions**

## 1.1 General description



The TB300 IR is a portable turbidity meter, based on the requirements of ISO 7027 (Water Quality – Determination of Turbidity). The instrument works with rechargeable batteries as well as with mains. As soon as the TB300 IR is connected with the adapter to the mains the batteries are charged.

The instrument featuring auto ranging over the range of 0.01 to 1100 NTU/FNU.

Calibration Standards which guarantee stability and reproducibility of the results. The turbidimeter is kept in the case with accessories and spares including the supplied. Always close the sample chamber for the protection of dust.

It is possible to update new software applications via internet ([www.orbeco.com](http://www.orbeco.com)). Please find detailed information at our homepage on the download-area.

## 1.2 Functional principle

The instrument measures turbidity in a range of 0.01 to 1100 NTU/FTU featuring auto ranging. The light source is an infrared LED (light emitting diode) with a wavelength of 860 nm.

The emitted light is reflected by turbidity in the sample. The scattered light will be detected under an angle of 90° by a photo diode.

This principle is part of ISO 7027.

The international Reference Standard for turbidity is a Formazin solution. Results related to these standards are indicated as FNU (Formazine Nephelometric Units).

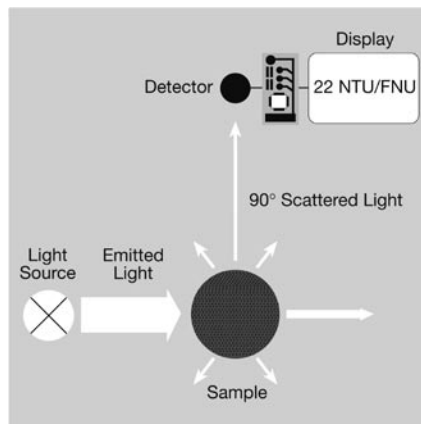

## 1.3 Factory adjustment

The turbidimeter TB300 IR is adjusted with Formazin Primary Standard at the factory and does not require user-calibration before use. See chapter 2.3.5 User-Calibration.

## 1.4 Important Notes

### 1.4.1 Guidelines for turbidity measurements

- Vials and caps should be cleaned thoroughly after each test to avoid influences. Minor residuals can cause errors.
- The outside of the vial must be clean and dry, before starting the Test. Wipe the vials with a smooth cloth to remove fingerprints or waterdrops.
- The vials must be positioned in the sample chamber with the mark on the vial aligned with the mark on the instrument.

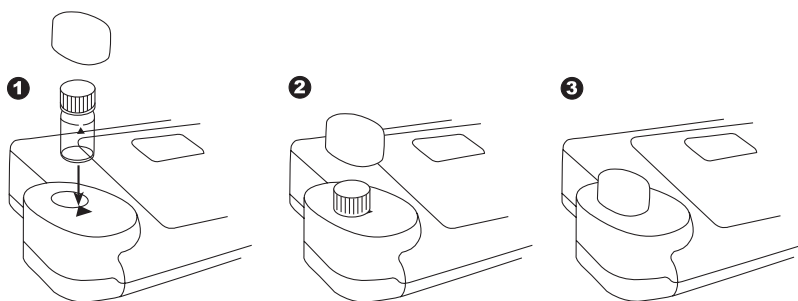

- Always perform test with closed vials.
- Bubbles on the inside of the vial lead to errors. See chapter 2.3.8.1 Removing bubbles (Degassing)
- Avoid spillage of water in the sample chamber. If water should leak into the instrument, it can destroy electronic components and cause corrosion.
- Contamination of the lens in the sample chamber can result in errors. Check at regular intervals – and if necessary – clean the light entry surfaces of the sample chamber using a moist cloth or cotton buds.
- Large temperature differences between the instrument and the environment can lead to errors – e.g. due to the formation of condensation in the area of the lens or on the vial.  
For best results, perform tests with sample temperatures between 20°C (68°F) and 25°C (77°F).
- To avoid errors caused by stray-light do not use the instrument in bright sunlight.
- Use the instrument in a clean, dust-free environment on a table, that is free of vibration / agitation.

## 1.4.2 Cleaning of vials & Sampling vessels

Vials, caps and sampling vessels should be cleaned thoroughly after each test to avoid influences. Minor residuals can cause errors.

### **Residuals:**

According to the type of measured sample it is necessary to clean the vial with different cleaning operations.

- Replace scratched vials immediately.
- Rinse vials continuous with deionized water after each measurement.
- Clean all glassware continuous with laboratory detergent and rinse with deionized water thoroughly.
- Clean heavy conterminations by filling the vials with 1:1 HCL followed by multiple rinses with distilled or deionized water.
- Allow vials to air dry.
- Touch vials at the top only to minimize dirt and fingerprints.
- Wipe the vials with a lint-free cloth to remove waterdrops and fingerprints.

## **Part 2**

# **Operating manual**

## 2.1 Operation

### 2.1.1 Commissioning

Before working with the TB300 IR insert the rechargeable batteries and the Lithium battery (part of delivery). The rechargeable batteries are not charged. See chapter 2.1.2 Saving data Important Notes, 2.1.3 Replacement of rechargeable batteries resp. Lithium battery. and 2.1.4 Charging the rechargeable batteries.

Before using the TB300 IR select language (mode 10), select mode 34 and perform "Delete Data". Set date and time (see chapter 2. Instruments settings).

### 2.1.2 Saving data – Important Notes

The Lithium battery saves data (stored results and photometer setting) if there is no power from the power supply from the rechargeable batteries or the mains adapter.

**Recommendation:** Exchange of the lithium battery every 5 years.

**Note:** When neither mains adapter nor batteries supply energy to the instrument, all stored data and settings will be lost, if the lithium battery is taken out.

**Recommendation:** Keep the instrument connected to mains adapter supply while changing the lithium battery.

### 2.1.3 Replacement of rechargeable batteries resp. Lithium-battery

1. Switch the instrument off.
2. If necessary remove vial from the sample chamber.
3. Place the instrument upside down on a clean and even surface.
4. Unscrew the two screws (A) of the battery compartment cover (B).
5. Lift battery compartment cover off.
6. If necessary remove old rechargeable batteries (C) and/or the Lithium-battery (D).
7. Place 7 new rechargeable batteries and/or the Lithium-battery.  
**Ensuring the correct polarity!**
8. Replace the battery compartment cover.
9. Tighten the screws carefully.

**CAUTION:**

Dispose the used batteries in accordance with all federal, state and local regulations.

### 2.1.4 Charging the rechargeable batteries

The rechargeable batteries are charged in the instrument. As soon the TB300 IR is connected by the adapter to the mains the batteries are charged. Empty rechargeable batteries should be charged in the instrument for at least 5 days. 10 charging and discharging cycles are necessary before the rechargeable batteries obtain their full capacity.

**It is possible to operate the instrument with the adaptor with or without inserted rechargeable batteries.**

## 2.1.5 Fuse

The instrument has a fuse (E) (type: 1 A, inert, 20 mm).

If an replacement is necessary proceed as described in "Replacement of rechargeable batteries resp. Lithium-battery". If the instrument can be operated with the mains adapter but not with the rechargeable batteries, the fuse could be defect (try new rechargeable batteries first).

## 2.1.6 Protective caps:

If not used protect the two connections against damage (e.g. corrosion) caused by environmental influences (e.g. dust or splashing) keep the protective caps in place (G).

(A) screws

(B) battery compartment cover

(C) rechargeable batteries: 7 Ni-MH-rechargeable batteries (Typ AA, 1100 mAh)

(D) battery: Lithium battery (Typ CR 2032, 3V)

(E) fuse





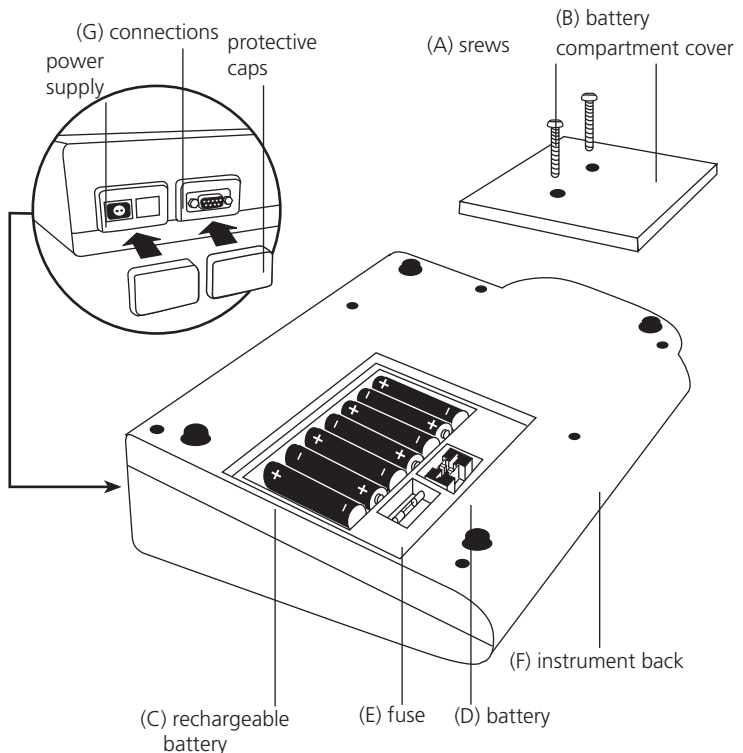







1 A, inert, 20 mm

(F) instrument



## 2.2 Overview of funktion keys

### 2.2.1 Overview

	Switch the instrument on or off
	Returning to previous menu
	Function key: description in the text if key available
	Function key: description in the text if key available
	Function key: description in the text if key available
	Confirming
	Menu of instrument settings and further functions
	Moving the Cursor ">>" up resp. down
	Storing of displayed test result
	Perform a measurement with signal averaging
	Perform a measurement
	Displaying date and time / user-countdown
	Perform a calibration

### 2.2.2 Displaying date and time

 Press [„clock“] key.

**19:27:20 15.06.2006**

The display shows:

After 15 seconds the turbidity meter reverts to the previous display automatically or press [] key or [ESC].



### 2.2.3 User-countdown

With this function the operator is able to define his own countdown.



Press [“clock”] key.

**19:20:20 15.06.2006**

The display shows time and date:



Press [“clock”] key.

**Count-Down**  
**mm : ss**  
**99 : 99**

The display shows:

Either press [↵] key to accept the last used user-count-down

or

press one number key to start entering a new value

**0 2 0 0**

The entering comprises two digits each.

Enter minutes and seconds

e.g.: 2 minutes, 0 seconds = [0][2][0][0]



Confirm with [↵] key.

**Count-Down**  
**02:00**

The display shows:

Start count down with [↵] key.

**Start: ↵**

After countdown has finished the Instrument reverts to the previous display automatically.

## 2.3 Operation mode



Switch the instrument on by pressing the [ON/OFF] key.

### Autotest ...

The instrument performs an electronic self-test.

### 2.3.1 Automatic switch off

The instrument automatically switches off after 20 minutes. This is indicated 30 seconds before by a beeper. Press any key to avoid the instrument switching off. As long as the instrument is working (for example countdown or printing) the automatic switch off is inactive.

## 2.3.2 Turbidity measurement

### 2.3.2.1 Read/ Avg key measurement with Signal Average



Press [Read/Avg] key to perform a test with signal average function.

By pressing the [Read/Avg] key Signal Average function is active. Signal averaging measures and averages 45 measurements. The signal averaging feature provides compensation for fluctuations caused by random drifting particles in the sample. The result is shown in **NTU**.

### 2.3.2.2 Read key - quick measurement



Press [Read] key to perform a quick test.

By pressing the [Read] key Signal averaging function is not active. The TB300 IR measures and averages 9 measurements. The result is shown in **NTU**.

### 2.3.2.3 Perform Turbidity measurement

Accurate turbidity measurements depend on good, consistent measurement techniques. Including operation with clean samples vials in good condition and removing air bubbles. Samples should be measured immediately to prevent changes in sample characteristics due to temperature shifts and settling.

#### Performance:

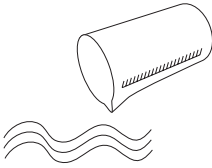

Take a representative sample in a clean container.



Fill a clean and dry vial with the water sample up to the mark (approx. 12 ml).



Cap the vial.

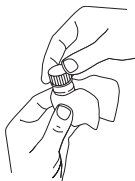

Take care to handle the vial by the top. Wipe the vial with a smooth and lint-free cloth to remove waterdrops and finger prints.



Switch on the instrument.

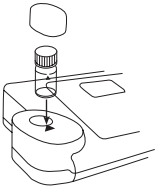

Place the vial in the sample chamber making sure that the positioning is correct.

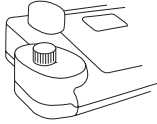

Close the sample chamber with the cap.



or



Press [Read/Avg] or [Read] key.

1.00 NTU

or

1.02 NTU\*

The result is shown in the display in NTU.

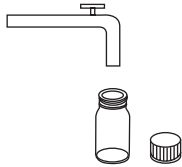

Remove the vial and clean it.

### 2.3.3 Storing results



Press [STORE] during the test result is displayed.

Code-No.:

-----

The display shows:

1 0 0 0 0 0

- We advise you to enter a numeric code (up to 6 digits long). (A code-No. can contain references to the operator or the sample-taking place.)



After entering confirm with [↵] key.

- If a code number is not necessary confirm by pressing [↵] directly. (The assignment for the Code-No. is then 0 automatically.)

The data set is stored with date, time, Code-No. and test result.

**Stored!**

The display shows:

The test result is then shown again.

**Note:**

The display shows the number of free data sets.

**Storage: 900  
free records left**

**Storage:  
only 29 free records left**

If there are less than 30 data sets free the display shows:

Clear the memory as soon as possible (see chapter 2.4.4 Delete stored results). If memory capacity is used up it would be impossible to save additional test results.

## 2.3.4 Printing results

If a printer is installed and switched on, it is possible to print out the test results (without saving before).

**F3**

Press F3 key.

The complete data set is printed: date, time, Code-No. and test result. Printing example:

```
2006-07-01 14:53:09  
Test No.:1  
Code-No.:1  
2,13 NTU*
```

The Test No. is a system number for data storage capacity and is set automatically if a test result is stored. It appears only at the print out.

## 2.3.5 User-calibration

### 2.3.5.1 When to calibrate

The turbidimeter was adjusted at the factory with Formazin Primary Standard and does not require user-calibration before use.

As the electrical and optical design of this instrument provides long-term stability the need for frequent calibration is minimized. Perform calibration with T-CAL every 3 month or if required more often.

### 2.3.5.2 Calibration Procedure

**Note:** Calibration may be canceled at any time by pressing the [ESC] key (not during a current Count-downs). The latest Calibration persist.

<b>Cal</b>	Press the [Cal] key to start the calibration.
<b>&lt;NTU adjustment&gt; standard: &lt;0,1 NTU</b>	Place the <0.1 NTU Standard in the sample chamber making sure that the marks aligned. Place the cover on the instrument.
<b>Read/ Avg</b>	Press [Read/Avg] key.
<b>Count-Down 1:00</b>	The Count-down starts. After the Count-down is finished the reading starts automatically.
<b>&lt;NTU adjustment&gt; standard: 20 NTU</b>	Place the 20 NTU Standard in the sample chamber making sure that the marks aligned. Place the cover on the instrument.
<b>Read/ Avg</b>	Press [Read/Avg] key.
<b>Count-Down 1:00</b>	The Count-down starts. After the Count-down is finished the reading starts automatically.
<b>&lt;NTU adjustment&gt; standard: 200 NTU</b>	Place the 200 NTU Standard in the sample chamber making sure that the marks aligned. Place the cover on the instrument.
<b>Read/ Avg</b>	Press [Read/Avg] key.
<b>Count-Down 1:00</b>	The Count-down starts. After the Count-down is finished the reading starts automatically.
<b>&lt;NTU adjustment&gt; standard: 800 NTU</b>	Place the 800 NTU Standard in the sample chamber making sure that the marks aligned. Place the cover on the instrument.

Read/  
Avg

Press [Read/Avg] key.

Count-Down  
1:00

The Count-down starts.  
After the Count-down is finished the reading starts automatically.

<NTU adjustment>  
store

Press [↵] key to store.

Press [Esc] key to cancel the calibration.



## 2.3.6 Calibration Standards

The T-CAL standards purchased with the instrument should be used to calibrate the instrument. It is possible to perform calibration with fresh dilutions of a Formazin Stock Solution. Using dilutions of a Formazin Stock Solution it is recommended to calibrate and measure with an indexed single vial or a set of matched vials.

### 2.3.6.1 T-CAL Standards - Correct Storage and Handling

For optimum results when using T-CAL Standards, adhere to the following recommendations:

#### Storing T-CAL Standards

- T-CAL standards should always be stored in their original vial.
- Store the vials preferably upright.
- The vials should be stored in their original box which should be closed when not being used.
- Store standards between 5 and 25°C.
- Avoid prolonged exposure to temperatures exceeding 35°C.
- Store away from direct sunlight.
- Always allow the standards to acclimatise to ambient instrument temperature before use (not to exceed 35°C).
- T-CAL standards have a shelf life of minimum 12 months.

#### Handling of T-CAL Standards

##### Using <0,1 NTU Standards

###### Attention:

- **Never shake or invert this <0.1 NTU standard.**
- After delivery allow the vial to stand for least 24 hours before use.
- If the standard has been shaken it can take several hours for all the bubbles to dissipate and we suggest the vial is left for at least 24 hours as outlined above.
- If the standard has been inverted accidentally wait at least 15 minutes before using.

## Preparing and Using Standards –infrequent use

**Note:** These instructions apply to all standards excepted the <0.1 NTU standard. If you are using the <0.1 NTU standard follow the instructions above. These instructions apply to standards that have been sitting undisturbed for more than one week or to new standards.

1. Shake the standard vigorously for 2-3 minutes.
2. Let the vial stand undisturbed for 5 minutes.
3. Invert the vial between 5-10 times.
4. Immediately place the vial in the sample chamber and wait for 1 minute (count down).

## Preparing and Using Standards –frequent use

**Note:** These instructions apply to all standards excepted the <0.1 NTU standard. If you are using the <0.1 NTU standard follow the instructions given above. These instructions apply to frequently used standards (daily or weekly usage).

1. Invert the vial 10 times.
2. Immediately place the vial in the sample chamber and wait for 1 minute (count down).

## 2.3.7 Formazin-Standards - Preparation and Handling

### 2.3.7.1 Preparation of Dilution Water

Collect at least 1000 ml of high quality water (e.g. distilled, demineralised or deionised water). Check the turbidity of the dilution water before use. If the turbidity is greater than 0.5 NTU (FNU) the water should be filtered with membrane filter (0.1 µm). Clean the required glassware with 1:1 hydrochloric acid and rinse several times with the dilution water.

### 2.3.7.2 Preparation of 4000 NTU Formazin-stock solution

We recommend to use a 4000 NTU Stock Solution that is available at specialised trade because these standards have high quality and you do not have to handle with the raw materials.

**Caution: Please observe handling instructions of MSDS. Gloves, goggles and breathing equipment must be worn!**

Prepare a Formazin Stock Solution from raw materials:

1. Dissolve 0.5 g Hydrazine sulfate ( $\text{NH}_2)_2\text{H}_2\text{SO}_4$  in 40 ml dilution water.
2. Dissolve 5.0 g Hexamethylenetetramine in 40 ml dilution water.
3. Transfer both solutions quantitatively in a 100 mL volumetric flask and fill to the mark with dilution water.
4. Mix the solution thoroughly.
5. Allow this solution to stand for at least 24 hours at  $25 \pm 3^\circ\text{C}$  ( $77 \pm 5^\circ\text{F}$ ) in a dark place (brown glass bottle).
6. The turbidity is developed over this period.

Formazin Stock Solution has a maximum shelf life of 1 year if stored correctly (at a dark place). Production of a Formazin Stock Solution described in „EN ISO 7027“ and „Standard Methods for Examination of Water and Wastewater“.

### 2.3.7.3 Preparation of dilutions from the 4000NTU Formazin-Stock solution

Prepare the dilutions from a 4000 NTU Formazin stock solution and dilution water.

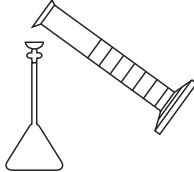
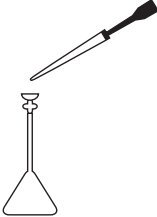
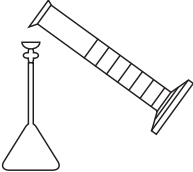
Standard	Step 1	Step 2	Step 3
			
<b>20 NTU</b>	Add 100 ml of dilution water to a clean 200 ml volumetric flask.	Pipette 1.00 ml well mixed 4000 NTU Formazin stock solution to this 200 ml flask.	Fill to the mark with dilution water. Close and mix the flask.
<b>200 NTU</b>	Add 50 ml of dilution water to a clean 100 ml volumetric flask.	Pipette 5.00 ml well mixed 4000 NTU Formazin stock solution to this 100 ml flask.	Fill to the mark with dilution water. Close and mix the flask.
<b>800 NTU</b>	50 ml of dilution water to a clean 100 ml volumetric flask.	Pipette 25.00 ml well mixed 4000 NTU Formazin stock solution to this 100 ml flask.	Fill to the mark with dilution water. Close and mix the flask.

Use class A volume pipet and glass flask.

**Use dilution water for the <0.1 NTU standard.**

## 2.3.8 Measurement techniques

### 2.3.8.1 Degassing - Removal of Bubbles

If the Turbidity is low it is important to remove air bubbles from the sample using one, or a combination of the following methods:

- Addition of a surfactant
- Application of a partial vacuum
- Application of heat
- Use of an ultrasonic bath

This procedure can influence the nature of the sample and therefore the turbidity reading.

Type of sample	Method	Description of the method	Notes:
Samples that are oversaturated with air	Addition of a surfactant	Surfactants minimize the surface tension of a sample, allowing entrained gases to disappear.	Particles in the sample settle more rapidly, so the sample must be swirled before being measured. Vigorous shaking causes the surfactant to foam.
Liquid samples without readily volatile components	Use of a particle vacuum	A vacuum can be created with the help of a clean, oil-free syringe or pump fitted onto the cuvette. The vacuum reduces the atmospheric pressure, so that trapped air bubbles can be removed.	Volatile components can escape from the sample. The vacuum may compound the air bubble problem in viscous samples.
Viscous samples	Use of an ultrasonic bath	The ultrasonic waves excite the sample, effectively remove air bubbles from most samples.	Ultrasonic waves can change the particles size in the sample, therefore changing the turbidity.
Very viscous samples	Heating the sample	Heating the sample makes it less viscous, air bubbles can disappear more easily. The sample has to cool to its original temperature.	Volatile components can disappear from the sample. The attributes of suspended particles change, therefore changing the turbidity.

### 2.3.8.2 Measurement of high turbidity values

High turbidity samples with more than 1100 NTU ("overrange") may be diluted. The dilution water should be a water with very low turbidity as described in chapter 2.3.7.1 "Preparing dilution water".

For accurate dilution proceed as follows:

Mix the water sample well and pipette x ml of the water sample (see table below) into a 100 ml volumetric flask. Fill with low turbidity water up to mark and mix gently.

Water sample (x ml)	Multiplication factor
10	10
25	4
50	2

Fill the diluted water sample into the vial, perform reading and multiply the displayed result with the multiplication factor.

**Note:**

**The dilution of water sample may alter the characteristics of the suspended particles and produce erroneous results.**

### 2.3.8.3 Measurement of low turbidity values

Accurate and repeatable measurements of low turbidity values depend on exact measurement techniques.

- Use a clean, unscratched and indexed vial.
- Rinse the vial three times with the sample.
- Allow the vial to stand for 1-5 minutes so that bubbles can disappear.
- Carefully invert the vial (so that settled particles disperse in the sample).
- Place the vial in the sample chamber and press the Read/Avg-key.
- Multiple perform the measurement, until is displayed a reproducible value (leave the vial in the sample chamber).

Note the smallest steady and reproducible value.

### 2.3.8.4 Indexing and matching sample vials

Matched sample vials are required to minimize the effects of optical variation from vial to vial glass. Alternatively an indexed single sample vial can be used for every measurement. Once vial orientation in the sample chamber is located, always use this new orientation mark for all measurements independent of the white pre-printed triangle mark.

### 2.3.8.5 Indexing a single sample vials



Fill a clean and dry vial up to the mark with Dilution Water (see chapter 2.3.7.1 Preparing Dilution Water).



Cap the vial.

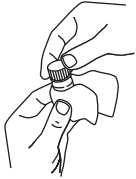

Hold the vial by the cap and wipe with a smooth, lint-free cloth to remove water spots and finger prints.



Switch the turbidimeter on.

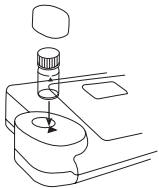

Place the vial in the sample chamber making sure that the marks are aligned.

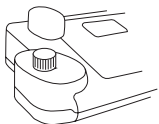

Place the cover on the instrument.



or



Press [Read/Avg] or [Read] key.

**1.00 NTU**

or

**1.02 NTU\***

Note the displayed result.

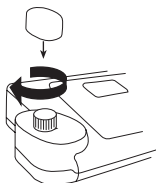

Rotate the vial in the sample chamber about 45°.

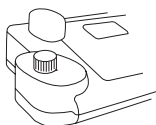

Place the cover on the instrument.



or



Press [Read/Avg] or [Read] key.

**1.00 NTU**

or

**1.02 NTU\***

Note the displayed result.

Repeat this procedure until the smallest NTU value is reading.

Mark the vial at this point. Use this orientation mark for all further measurements.

**Note:**

Assess the indication "Underrange" as 0.00 NTU.

### 2.3.8.6 Indexing a set of sample cells

1. Fill several clean and dry vials until the mark with dilution water.
2. Cap the vials.
3. Hold the vials by the cap and wipe with a smooth, lint-free cloth to remove Water spots and finger prints.
4. Switch the turbidimeter on.
5. Place the first vial in the sample chamber making sure that the marks are aligned.
6. Place the cover on the instrument.
7. Press [Read/Avg] or [Read] key.
8. Note the displayed result.

9. Rotate the vial in the sample chamber about 45°.
10. Place the cover on the instrument.
11. Press [Read/Avg] or [Read] key.
12. Note the displayed result.
13. Repeat this procedure as the smallest NTU value is reading.
14. Mark the vial.
15. Indexing more vials repeat point 1. to 12. for each vial.
16. Repeat this procedure until the reading matches the first vial reading within  $\pm 0,01$  NTU.
17. Mark the vial.
18. Repeat this procedure to match other cells.

**Note:**

It may not be possible to match all cells due to variability in glass.

## 2.4 Settings <MODE-Menü>

### Table of MODE-Functions

Mode-Function	No.	Description	Page
Clock	12	Setting date and time	38
Delete data	34	Deleting all stored results	35
Key beep	11	Switching the acoustic signal on/off to indicate key-pressing	37
Language	10	Selecting language	36
LCD contrast	80	Setting the display contrast	31
Print	20	Printing all stored results	33
Print Code-No.	22	Print only results of a selected Code-No. range	32
Print date	21	Print only results of a selected time period	34
Printing parameters	29	setting of printing options	39
Signal beep	14	Switching the acoustic signal on/off to indicate end of reading	39
Storage	30	Displaying all stored results	30
Storage Code-No.	32	Displaying only results of a selected Code.No. range	28
Storage date	31	Displaying only results of a selected time period	28
System-info	91	Information about the instrument e.g. current software-version	29

**The selected settings are kept by the instrument also after it was switched off. To change instrument settings a new setting is required.**

## 2.4.1 blank because of technical requirements

### 2.4.2 Instrument basic settings 1

#### Selecting a language



Press [MODE] [1] [0] keys.



Confirm with [↵] key.



The display shows:

Press arrow key [▼] or [▲] to select the required language from the displayed list.



Confirm with [↵] key.

#### Key-beep



Press [MODE] [1] [1] keys.



Confirm with [↵] key.

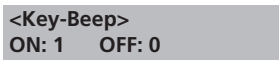

The display shows:



- Press [0] key to switch the key beep off.



- Press [1] key to switch the key beep on.



Confirm with [↵] key.

## Setting date and time



Press [MODE] [1] [2] keys.



Confirm with [↵] key.

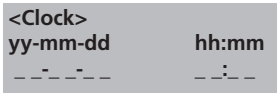

The display shows:

The entering comprises two digits each.

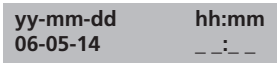

Enter year, month and day,

e.g.: 14. May 2006 = [0][6][0][5][1][4]

The display shows:



Enter hours and minutes

e.g.: 3.07 p.m. = [1][5][0][7]



Confirm with [↵] key.

### Note:

While conforming date and time with [↵] key the seconds are adjusted to zero automatically.

## Signal-beep

Performing a measurement takes several seconds. The instrument indicates the end of measuring by a short beep.



Press MODE [1] [4] keys.



Confirm with [↵] key.

<Signal-Beep>  
ON: 1 OFF: 0

The display shows:



- Press [0] key to switch the signal-beep off.



- Press [1] key to switch the signal-beep on.



Confirm with [↵] key.

## 2.4.3 Printing of stored results

### Printing all results



Press MODE [2] [0] keys.



Confirm with [↵] key.

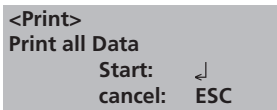

The display shows:



Press [↵] key for printing out all stored test results.



The display shows e.g.:

After printing the instrument goes back to mode menu automatically.

#### Note:

All stored data are printed out.

## Printing results of a selected time period

Mode

2

1

Press MODE [2] [1] keys.



Confirm with [↵] key.

<Print>  
sorted: date  
from yy-mm-dd

The display shows:

Enter year, month and day for the first day of the required period, e.g.: 14 May 2006 = [0][6][0][5][1][4]



Confirm with [↵] key.

to yy-mm-dd

The display shows:

Enter year, month and day for the last day of the required period, e.g.: 19 May 2006 = [0][6][0][5][1][9]



Confirm with [↵] key.

from 2006-05-14  
to 2006-05-19  
Start: ↵  
cancel: ESC

The display shows:

Press [↵] key and all stored results in the selected date range are printed.

After printing the instrument goes back to mode menu automatically.

### Note:

It is possible to cancel the entering by [ESC].

If you want to print only results of one day enter the same date twice to characterise the period.

## Printing results of a selected Code-No. range



Press MODE [2] [2] keys.



Confirm with [↵] key.

<Print>  
sorted: Code-No.  
from \_ \_ \_ \_ \_

The display shows:

Enter numeric code number (up to 6 places) for the first required Code-No., e.g.: [1].



Confirm with [↵] key.

to \_ \_ \_ \_ \_

The display shows:



Enter numeric code number (up to 6 places) for the last required Code-No., e.g.: [1] [0].

Confirm with [↵] key.

from 000001  
to 000010  
Start: ↵  
cancel: ESC

The display shows:

Press [↵] key and all stored results in the selected Code-Number range are printed.

After printing the instrument goes back to mode menu automatically.

### Note:

It is possible to cancel the entering by [ESC].

If you want to print only results of one code number enter the same code number twice.

If you want to print all results without code no. (code no. is 0) enter Zero [0] twice.

## Printing Parameter



Press MODE [2] [9] keys.



Confirm with [↵] key.

```
<printing parameter>
1: Flow control
2: Baud rate
cancel:          ESC
```

The display shows:



Press [1] key to select "Protocol".

```
<Flow Control>
is: Hardware
select:  [▲] [▼]
save:    ↵
cancel:  ESC
```

The display shows:



Press arrow key [▼] or [▲] to select the required Protocol (Xon/Xoff, Hardware, no control)



Confirm with [↵] key.



Finish with **ESC** key.

Flow Control will be set to the selection displayed at "is".



Press [2] key to select "Baudrate".

```
<Baud rate>
is: 19200
select: [▲] [▼]
save:   ↵
cancel: ESC
```

The display shows:



Press arrow key [▼] or [▲] to select the required Baud rate. (600, 1200, 2400, 4800, 9600, 14400, 19200)



Confirm with [↵] key.



End with **ESC** key.

Back to Mode-Menu with **ESC** key.

**Note:**

Select "Hardware" as Flow control and "9600" as Baud rate for using the printer **DPN 2335**.

Select "Hardware" as Flow control and "19200" as Baud rate for using the printer **DP 1012**. For setting of the printer see chapter 2.5.1 Connection to a printer.

## 2.4.4 Recall / delete stored results

### Recall all stored results



Press [MODE] [3] [0] keys.



Confirm with [↵] key.

<Storage>  
display all data  
Start: ↵ cancel: ESC  
print: F3  
print all: F2

The display shows:

The stored data sets are displayed in chronological order, started with the latest stored test result.

- Press [↵] key and all stored results are displayed.
- Press [F3] key to print the displayed result.
- Press [F2] key to print all selected results.
- End with [ESC].
- Press arrow key [▼] to display the following test result.
- Press arrow key [▲] to display the previous test result.



no Data

If there are no test results in memory the display shows:

## Recall results of a selected time period

Mode

3

1

Press MODE [3] [1] keys.



Confirm with [↵] key.

```
<Storage>
sorted: date
from yy-mm-dd
_ _ - _ - _
```

The display shows:

Enter year, month and day for the for the first day of the required period, e.g.: 14 May 2006 = [0][6][0][5][1][4]



Confirm with [↵] key.

```
to yy-mm-dd
_ _ - _ - _
```

The display shows:

Enter year, month and day for the last day of the required period, e.g.: 19 May 2006 = [0][6][0][5][1][9]



Confirm with [↵] key.

```
from 2006-05-14
to 2006-05-19
Start:  ↵ cancel: ESC
print: F3
print all: F2
```

The display shows:

- Press [↵] key and all stored results in the selected date range are displayed.
- Press [F3] key to print the displayed result.
- Press [F2] key to print all selected results.
- End with [ESC].

### Note:

It is possible to cancel the entering by [ESC].

If you want to recall only results of one day enter the same date twice to characterise the time period.

## Recall results of a selected Code-No. range



Press MODE [3] [2] keys.



Confirm with [↵] key.

<Storage>  
sorted: Code-No.  
from \_\_\_\_\_

The display shows:

Enter numeric code number (up to 6 places for the first required Code-No., e.g.: [1]).



Confirm with [↵] key.

to \_\_\_\_\_

The display shows:

Enter numeric code number (up to 6 places) for the last required Code-No., e.g.: [1] [0].



Confirm with [↵] key.

from 000001  
to 000010  
Start: ↵ cancel: ESC  
print: F3  
print all: F2

The display shows:

- Press [↵] key and all stored results in the selected Code-No. range are displayed.
- Press [F3] key to print the displayed result.
- Press [F2] key to print all selected results.
- End with [ESC].

### Note:

It is possible to cancel the entering by [ESC].

If you want to recall only results of one code number enter the same code number twice.

If you want to recall all results without code no. (code no. is 0) enter Zero [0] twice.

## Delete stored results

Mode **3** **4**

Press MODE [3] [4] keys.



Confirm with [↵] key.

<Delete data>  
Delete all data?  
YES : 1 NO : 0

The display shows:

**0**

- Press [0] key to retain the data sets in memory.

**1**

- After pressing key [1] the following acknowledgment is displayed:

<Delete data>  
Delete data ↵  
Do not delete: ESC

Press [↵] key to delete.

**ATTENTION:**  
**All stored test results are deleted.**

or cancel without deleting data by pressing [ESC] key.

## 2.4.5 – 2.4.8 blank because of technical requirements

### 2.4.9 Instrument basic settings 2

#### Adjusting display contrast



Press [MODE] [8] [0] keys.



Confirm with [↵] key.



The display shows:



- Press arrow key [▲] to increase contrast of the LCD display.



- Press arrow key [▼] to decrease contrast of the LCD display.



Confirm with [↵] key..

### 2.4.10 Instrument special functions/service

#### Instrument-Information



Press [MODE] [9] [1] keys.



Confirm with [↵] key.

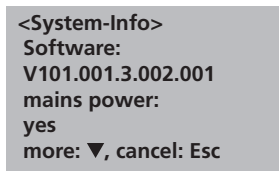

This function informs you about the current software version, about the current detected mains power supply, about the number of performed tests and free memory capacity.

[▼]

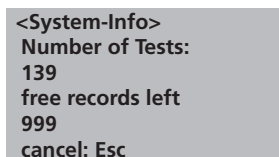

Finish with **ESC** key.

## 2.5 Data transfer

Switch the instrument and the personal computer or printer off. Connect the instrument (RS232 interface) and the serial interface of the personal computer or printer using a cable in line with the specified assignment (see technical data). The cable for connection to a personal computer is included in delivery contents.

### 2.5.1 Connection to a printer

Printer with a serial connection are suitable for connection with the instrument (see chapter 3.4 Technical data interface).

A suitable paper label printer is the printer DPN 2335.

Before using the printer **DPN 2335** with the instrument you should change the following standard adjustments:

(Detailed information of changing the adjustment you will find in the printer manual).

Baud-rate:	<b>9600</b>
Parity:	<b>None</b>
Data bits:	<b>8</b>

**Note:** The printer must be connected and switched on before printing.

**Caution:** Adjust printing parameter in Mode 29. See chapter 2.4.3 Printing Parameter.

### 2.5.2 Data transfer to a personal computer

Transferring test results from the instrument to a personal computer requires a transfer program, e.g. HyperTerminal.

Please find detailed information at our homepage on the download-area.

### 2.5.3 Internet-Updates

It is possible to update new software applications and additional languages via internet. Please find detailed information at our homepage on the download-area.

**Remark:**

To prevent loss of stored test results store or print out them before performing an Update.

# **Part 3**

# **Enclosure**

## 3.1 Unpacking the instrument

Carefully inspect all items to ensure that every part of the list below is present and no visible damage has occurred during shipment. If there is any damage or something is missing, please contact your local distributor immediately.

## 3.2 Delivery content

Standard content of the Turbidimeter:

- 
- 1 Turbidimeter in plastic case
- 1 Cap for Turbidimeter
- 2 Protective caps for connections
- 1 Rechargeable battery set (7 Ni-MH rechargeable batteries; Type AA; 1100 mAh)
- 1 Lithium battery (CR 2032; 3V)
- 1 Mains adapter, (100 – 240 V, 50 – 60 Hz)
- 1 Cable for connection to PC
- 4 Round vials with cap, height 54 mm, Ø 24 mm
- 1 Beaker cup, plastic, 100 ml
- 1 Standard T-Cal <0.1 NTU
- 1 Standard T-Cal 20 NTU
- 1 Standard T-Cal 200 NTU
- 1 Standard T-Cal 800 NTU
- 1 Screwdriver
- 1 Instruction manual
- 1 Short manual
- 1 Guarantee declaration

Please see the General Catalogue for details of available accessories and spare parts.

## 3.3 blank because of technical requirements

### 3.4 Technical data

Display	Graphic-Display (7-line, 21-characters)
Serial Interface	serial RS232 for printer- and PC-connection; 9-pin D-sub-male connector, data format ASCII, 8-bit Data, no parity, 1 start-bit, 1 stop-bit, baud rate and protocol: adjustable Pin assignation: Pin 1 = free                      Pin 6 = free Pin 2 = Rx Data                  Pin 7 = RTS Pin 3 = Tx Data                  Pin 8 = CTS Pin 4 = free                      Pin 9 = free Pin 5 = GND
Light source	LED $\lambda = 860$ nm and photo sensor amplifier in protected cell compartment.
Principle	Nephelometric (Non Ratio)
Range	0.01 – 1100 NTU <sup>1)</sup>
Resolution	0.01 – 9.99 NTU = 0.01 NTU 10.0 – 99.9 NTU = 0.1 NTU 100 – 1100 NTU = 1 NTU
Accuracy	$\pm 2$ % of reading or $\pm 0.01$ NTU from 0.01 to 500 NTU $\pm 5$ % of reading from 500 to 1100 NTU
Repeatability	$\pm 1$ % of reading or $\pm 0.01$ NTU which ever is greater
Operation	Acid and solvent resistant touch-sensitive keyboard with integral beeper as acoustic indicator.
Power supply	7 Ni-MH rechargeable batteries (Type AA with 750 mAh); external main adapter (Input: 100–240 V, 50–60 Hz; Output: 15V=/530 mA) Lithium battery (CR 2032, 3V); for keeping data if there is no power supply from the rechargeable batteries or the main adapter.
Auto off	20 minutes after last function, 30 seconds acoustical signal before switching off.
Charging time	approx. 10 hours
Dimensions	approx. 265 x 195 x 70 mm (unit) approx. 440 x 370 x 105 mm (case)
Weight (unit)	approx. 1000 g (with main adapter and rechargeable batteries)
Working condition	5–40°C at max. 30–90% relative humidity (without condensation)
Language options	German, English, French, Spanish, Italian; further languages via Internet-Update
Storage capacity	ca.1000 data sets

<sup>1)</sup>FNU is equivalent to "Non Ratio" instruments.

#### **Subject to technical modification!**

**To ensure maximum accuracy of test results, always use the reagent systems supplied by the instrument manufacturer.**

### 3.5 Abbreviations

<b>Abbreviation</b>	<b>Definition</b>
Read/Avg	Signal Average function
NTU	Nephelometric Turbidity Unit
FTU	Formazine Turbidity Unit
FNU	Formazine Nephelometric Units
FAU	Formazine Attenuation Units
ASBC	American Society of Brewing Chemists
EBC	European Brewery Convention
mg/l	Milligram per litre
ppm	Parts per million

## 3.6 Trouble-shooting

### 3.6.1 Operating messages in the display / error display

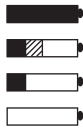
Display	Meaning	Trouble shooting
Overrange	Reading is exceeding the range too much light on the photo cell.	<ul style="list-style-type: none"> <li>• If possible dilute sample.</li> <li>• Cell chamber lid closed?</li> <li>• Repeat measurement with closed lid.</li> </ul>
Underrange	result is under detection limit	---
Storagesystem error use Mode 34	mains power fails or is not existing.	Insert or change Lithium battery. Delete data with Mode 34.
Capacity of rechargeable battery 	<p>Full Capacity</p> <p>Warning automaticly every 3 min.</p> <p>Warning automaticly every 12 min.</p> <p>Warning automaticly, the instrument switches of</p>	<ul style="list-style-type: none"> <li>• Capacity of rechargeable battery may be too low.</li> <li>• Charge the rechargeable batteries.</li> <li>• Operate imstrument with mains adapter.</li> </ul>
Printer „Timeout“	<ul style="list-style-type: none"> <li>• Printer switched off.</li> <li>• No conection.</li> </ul>	<ul style="list-style-type: none"> <li>• Connect printer.</li> <li>• Check connections.</li> <li>• Switch printer on.</li> </ul>
Instrument can be operated with the mains adapter but not with the rechargeable batteries.	Rechargeable batteries are not charged or defect. Fuse (Typ A, inert, 20 mm) may be defect.	Charge rechargeable batteries or change them. If the problem still exists change fuse.

---

**Orbeco-Hellige Inc.,  
6456 Parkland Drive, Sarasota, Florida 34243  
Phone: 941-756-6410, Fax: 941-727-9654  
service@orbeco.com, www.orbeco.com**